

DE Montageanleitung	CZ Návod na montáž
FR Instructions de montage	DK Monteringsvejledning
NL Montage instructie	FI Sumuvalosarjan
GB Fitting instruction	GR Οδηγίες τοποθέτησης
ES Instrucciones de montaje	NO Monteringsanvisning
IT Istruzioni di montaggio	PL Instrukcja montażu
SE Monteringsinstruktioner	RU Инструкция по установке
SK Návod na montáž	RO Instrucțiuni de montaj

DE	Beachten Sie bitte, dass bei Schäden in Folge unsachgemäßen Einbaus sämtliche Garantieansprüche erlöschen, insbesondere solche, die das Produkthaftungsgesetz betreffen.	Das Recht zu Änderungen an Inhalt von Montagesatz und Einbauanleitung ohne Vorankündigung bleibt vorbehalten. Lesen Sie vor dem Einbau diese Anleitung sorgfältig durch.
FR	Nous tenons à insister tout particulièrement sur le fait que si ce produit n'est pas correctement assemblé par un technicien compétent, aucun droit de compensation ne sera recevable en cas de dommages, notamment les droits en vertu de la loi concernant la responsabilité à l'égard des produits.	Le contenu de ce produit, ainsi que des guides de montage qui les accompagnent est sujet à modifications sans préavis ; lisez attentivement ces instructions avant de procéder à l'installation.
NL	De installatie moet worden uitgevoerd door een erkende, competente installateur. Incorrecte montage kan leiden tot het vervallen van elk recht op schadecompensatie, met name die met betrekking tot product aansprakelijkheid.	De inhoud van deze kits en de installatiehandleidingen kunnen worden gewijzigd zonder kennisgeving. Zorg er voor, dat u deze instructies hebt gelezen en volledig begript voordat u met de installatie begint.
GB	We expressly point out that assembly not carried out properly by a competent installer will result in cancellation of any right to damage compensation, in particular those arising by virtue of the product liability act.	Contents of these kits and their fitting manuals are subject to alteration without notice, please ensure that these instructions are read and fully understood before commencing installation.
ES	Una vez más, hacemos hincapié en el hecho de que si este producto no es instalado correctamente por un técnico cualificado, se anulará cualquier derecho de compensación por posibles daños, especialmente los relativos a la legislación vigente sobre este tipo de productos.	El contenido de los kits y sus correspondientes manuales de montaje están sujetos a posibles modificaciones sin previo aviso. Es importante que lea con atención todas las instrucciones y que las entienda perfectamente antes de iniciar la instalación.
IT	Vi informiamo che, in caso di installazione scorretta e/o non eseguita da un installatore competente, il Cliente perderà ogni diritto a un eventuale rimborso danni e, specificamente, ogni diritto previsto dalle leggi sulla responsabilità di prodotto.	I contenuti di questi kit e i relativi manuali di installazione sono soggetti a modifica senza preavviso. Si raccomanda di leggere attentamente e integralmente tali istruzioni e di sincerarsi di averle comprese prima di procedere all'installazione.
SE	Vi meddelar att montering, som inte görs fackmannamässigt, kommer att häva rätten till kompensation för skador, speciellt rättigheter enligt lagen om produktansvar.	Innehållet i dessa satser och deras bruksanvisningar kan komma att ändras utan förvarning. Vänligen läs dessa anvisningar noga innan du påbörjar monteringen.
CZ	Upozorňujeme, že instalace provedená nesprávně nebo nekompetentní osobou, ruší veškerá práva na kompenzaci škod, obzvláště těch způsobených poruchou produktu.	Obsah těchto sad a návody na jejich montáž podléhají změnám bez předchozího upozornění. Prosím, ujistěte se, že jste si pokyny před instalací přečetli a dostatečně jim rozumíte.
DK	Det skal understreges, at montering, der udføres af en ikke-kvalificeret montør, medfører bortfald af enhver ret til erstatning særligt i forbindelse med erstatnings-krav, der måtte opstå i kraft af loven om produktansvar.	Sættenes indhold og monteringsvejledninger kan ændres uden varsel, og vejledningerne skal derfor læses og forstås, før monteringen påbegyndes.
FI	Jos asennuksen suorittaa joku muu kuin pätevä ammattilainen, tämä kumooa asiakkaan oikeuden vahingonkorvauksiin, erityisesti sellaisiin, jotka perustuvat tuotevastuulakiin.	Kiinnityssarjan sisältöä ja asennusohjeita voidaan muuttaa siitä etukäteen ilmoittamatta. Näihin ohjeisiin tulee perehtyä huolellisesti ennen asennuksen aloittamista.
GR	Θα πρέπει να τονιστεί ότι συναρμολόγηση που δεν πραγματοποιείται σωστά και από ειδικευμένο εγκαταστάτη οδηγεί σε ακύρωση των όποιων δικαιωμάτων αποζημίωσης έναντι ζημιών και ιδιαίτερα αυτών που προκύπτουν σύμφωνα με το νόμο περί ευθύνης προϊόντος.	Τα περιεχόμενα αυτών των kit και τα εγχειρίδια τοποθέτησης υπόκεινται σε αλλαγές χωρίς προειδοποίηση. Βεβαιωθείτε ότι ο οδηγός αυτές έχουν διαβάσει και έχουν γίνει απολύτως κατανοητές προτού ξεκινήσετε την εγκατάσταση.
NO	Vi bemerker at montasje som ikke utføres korrekt, av en kompetent installatør, vil resultere i annullering av all rett til erstatning for enhver skade, spesielt de som oppstår av arten produktansvar.	Innholdene i disse sett og deres monteringsanvisninger kan endres uten forvarsel. Vennligst påse at disse instruksjonene leses grundig og er forstått innen installasjonen startes.
PL	Pragniemy wyrażnie podkreślić, że nieprawidłowy montaż przeprowadzony przez niekompetentne osoby będzie podstawą rezygnacji z ewentualnego prawa do odszkodowania, w szczególności wynikających z mocy ustawy o odpowiedzialności za produkt.	Zawartość opisywanych zestawów i instrukcje ich montażu mogą ulec zmianie bez uprzedzenia; przed rozpoczęciem instalacji należy zapoznać się z instrukcjami i upewnić się, że zostały w pełni zrozumiałe.
RU	Обратите внимание, что при повреждениях, возникших в результате неправильного монтажа, истекают все виды гарантии, в частности, касающиеся закона, регулирующего ответственность за качество продукции.	Производитель сохраняет за собой право на изменение содержания монтажного комплекта и инструкции по установке без предварительного уведомления. Внимательно прочитайте инструкцию перед началом установки.
SK	Upozorňujeme, že inštalácia vykonaná nesprávne alebo nekompetentnou osobou, ruší všetky práva na kompenzáciu škôd, obzvlášť tých spôsobených poruchou produktu.	Obsah týchto sad a návody na ich montáž podliehajú zmenám bez predchádzajúceho upozornenia. Prosím, uistite sa, že ste si pokyny pred inštaláciou prečítali a dostatočne ste im porozumeli.
RO	Vă atragem atenția că montajul efectuat incorect sau de către personal neautorizat duce la anularea oricărui drept de compensare a eventualelor daune produse utilizatorului.	Conținutul acestor pachete precum și al instrucțiunilor de montaj pot fi modificate fără preaviz. Vă rugăm să vă asigurați că aceste instrucțiuni sunt citite și înțelese înainte de a începe instalarea.

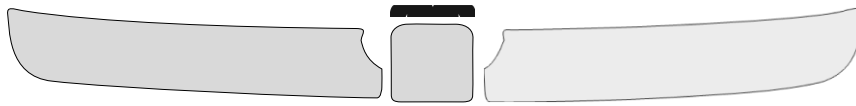

INDEX	
FR	EN
1. Avant de commencer	1. Before starting
2. Préparation de la solution	2. Preparation of the solution
3. Application	3. Application
4. Nettoyage	4. Cleaning
5. Entretien	5. Maintenance
6. Sécurité	6. Safety
7. Informations complémentaires	7. Additional information
8. Remarque	8. Note
9. Informations techniques	9. Technical information
10. Informations de contact	10. Contact information
11. Informations de recyclage	11. Recycling information
12. Informations de sécurité	12. Safety information
13. Informations de transport	13. Transport information
14. Informations de stockage	14. Storage information
15. Informations de distribution	15. Distribution information
16. Informations de vente	16. Sales information
17. Informations de service client	17. Customer service information
18. Informations de garantie	18. Warranty information
19. Informations de retour	19. Return information
20. Informations de recyclage	20. Recycling information
21. Informations de sécurité	21. Safety information
22. Informations de transport	22. Transport information
23. Informations de stockage	23. Storage information
24. Informations de distribution	24. Distribution information
25. Informations de vente	25. Sales information
26. Informations de service client	26. Customer service information
27. Informations de garantie	27. Warranty information
28. Informations de retour	28. Return information
29. Informations de recyclage	29. Recycling information
30. Informations de sécurité	30. Safety information
31. Informations de transport	31. Transport information
32. Informations de stockage	32. Storage information
33. Informations de distribution	33. Distribution information
34. Informations de vente	34. Sales information
35. Informations de service client	35. Customer service information
36. Informations de garantie	36. Warranty information
37. Informations de retour	37. Return information
38. Informations de recyclage	38. Recycling information
39. Informations de sécurité	39. Safety information
40. Informations de transport	40. Transport information
41. Informations de stockage	41. Storage information
42. Informations de distribution	42. Distribution information
43. Informations de vente	43. Sales information
44. Informations de service client	44. Customer service information
45. Informations de garantie	45. Warranty information
46. Informations de retour	46. Return information
47. Informations de recyclage	47. Recycling information
48. Informations de sécurité	48. Safety information
49. Informations de transport	49. Transport information
50. Informations de stockage	50. Storage information
51. Informations de distribution	51. Distribution information
52. Informations de vente	52. Sales information
53. Informations de service client	53. Customer service information
54. Informations de garantie	54. Warranty information
55. Informations de retour	55. Return information
56. Informations de recyclage	56. Recycling information
57. Informations de sécurité	57. Safety information
58. Informations de transport	58. Transport information
59. Informations de stockage	59. Storage information
60. Informations de distribution	60. Distribution information
61. Informations de vente	61. Sales information
62. Informations de service client	62. Customer service information
63. Informations de garantie	63. Warranty information
64. Informations de retour	64. Return information
65. Informations de recyclage	65. Recycling information
66. Informations de sécurité	66. Safety information
67. Informations de transport	67. Transport information
68. Informations de stockage	68. Storage information
69. Informations de distribution	69. Distribution information
70. Informations de vente	70. Sales information
71. Informations de service client	71. Customer service information
72. Informations de garantie	72. Warranty information
73. Informations de retour	73. Return information
74. Informations de recyclage	74. Recycling information
75. Informations de sécurité	75. Safety information
76. Informations de transport	76. Transport information
77. Informations de stockage	77. Storage information
78. Informations de distribution	78. Distribution information
79. Informations de vente	79. Sales information
80. Informations de service client	80. Customer service information
81. Informations de garantie	81. Warranty information
82. Informations de retour	82. Return information
83. Informations de recyclage	83. Recycling information
84. Informations de sécurité	84. Safety information
85. Informations de transport	85. Transport information
86. Informations de stockage	86. Storage information
87. Informations de distribution	87. Distribution information
88. Informations de vente	88. Sales information
89. Informations de service client	89. Customer service information
90. Informations de garantie	90. Warranty information
91. Informations de retour	91. Return information
92. Informations de recyclage	92. Recycling information
93. Informations de sécurité	93. Safety information
94. Informations de transport	94. Transport information
95. Informations de stockage	95. Storage information
96. Informations de distribution	96. Distribution information
97. Informations de vente	97. Sales information
98. Informations de service client	98. Customer service information
99. Informations de garantie	99. Warranty information
100. Informations de retour	100. Return information
101. Informations de recyclage	101. Recycling information
102. Informations de sécurité	102. Safety information
103. Informations de transport	103. Transport information
104. Informations de stockage	104. Storage information
105. Informations de distribution	105. Distribution information
106. Informations de vente	106. Sales information
107. Informations de service client	107. Customer service information
108. Informations de garantie	108. Warranty information
109. Informations de retour	109. Return information
110. Informations de recyclage	110. Recycling information
111. Informations de sécurité	111. Safety information
112. Informations de transport	112. Transport information
113. Informations de stockage	113. Storage information
114. Informations de distribution	114. Distribution information
115. Informations de vente	115. Sales information
116. Informations de service client	116. Customer service information
117. Informations de garantie	117. Warranty information
118. Informations de retour	118. Return information
119. Informations de recyclage	119. Recycling information
120. Informations de sécurité	120. Safety information

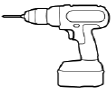

+



0,5 l

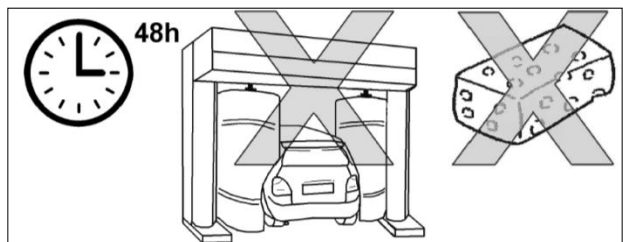
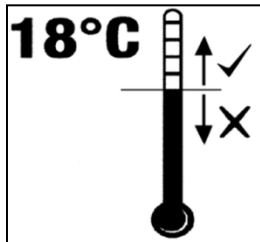

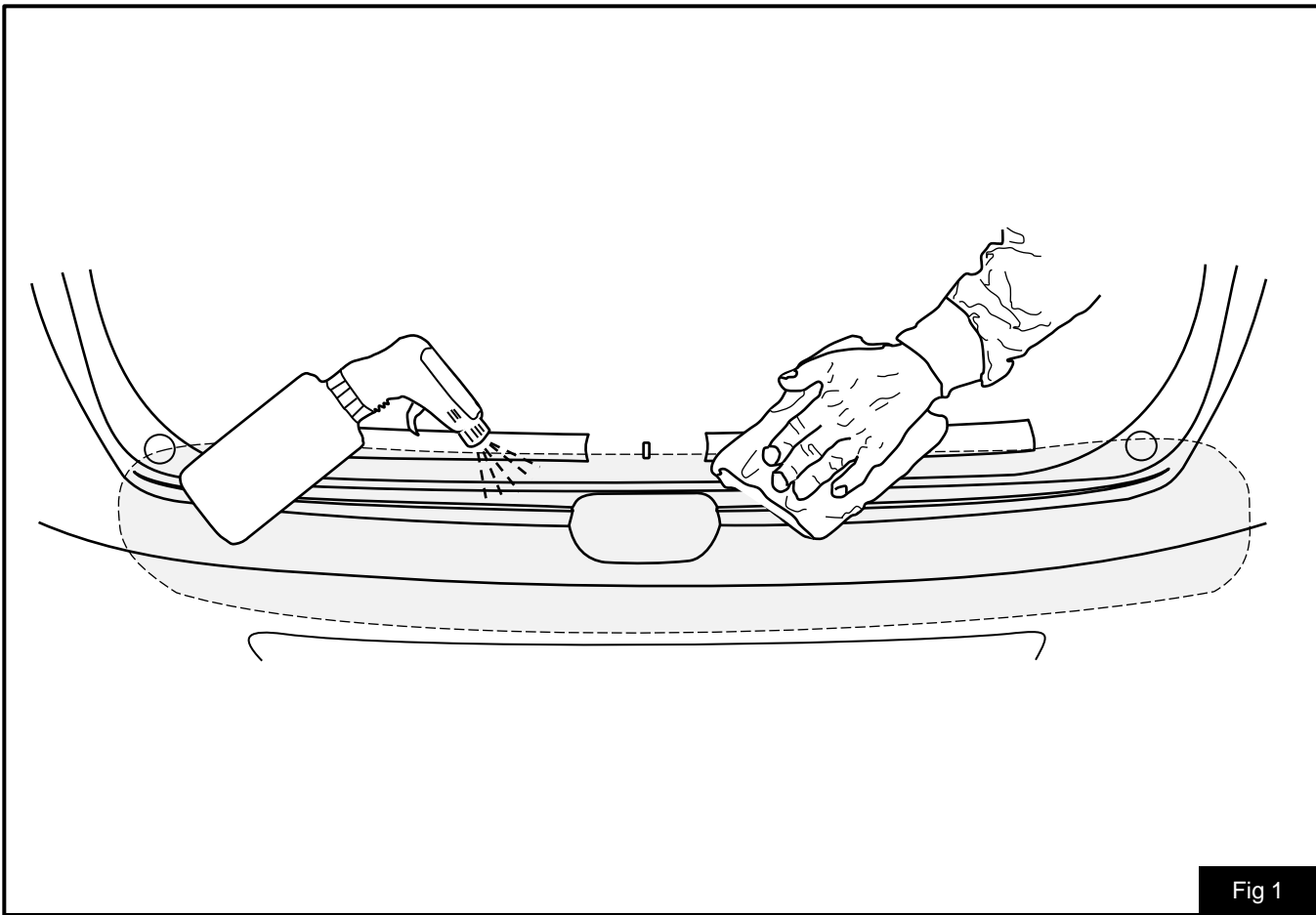

Fig 1

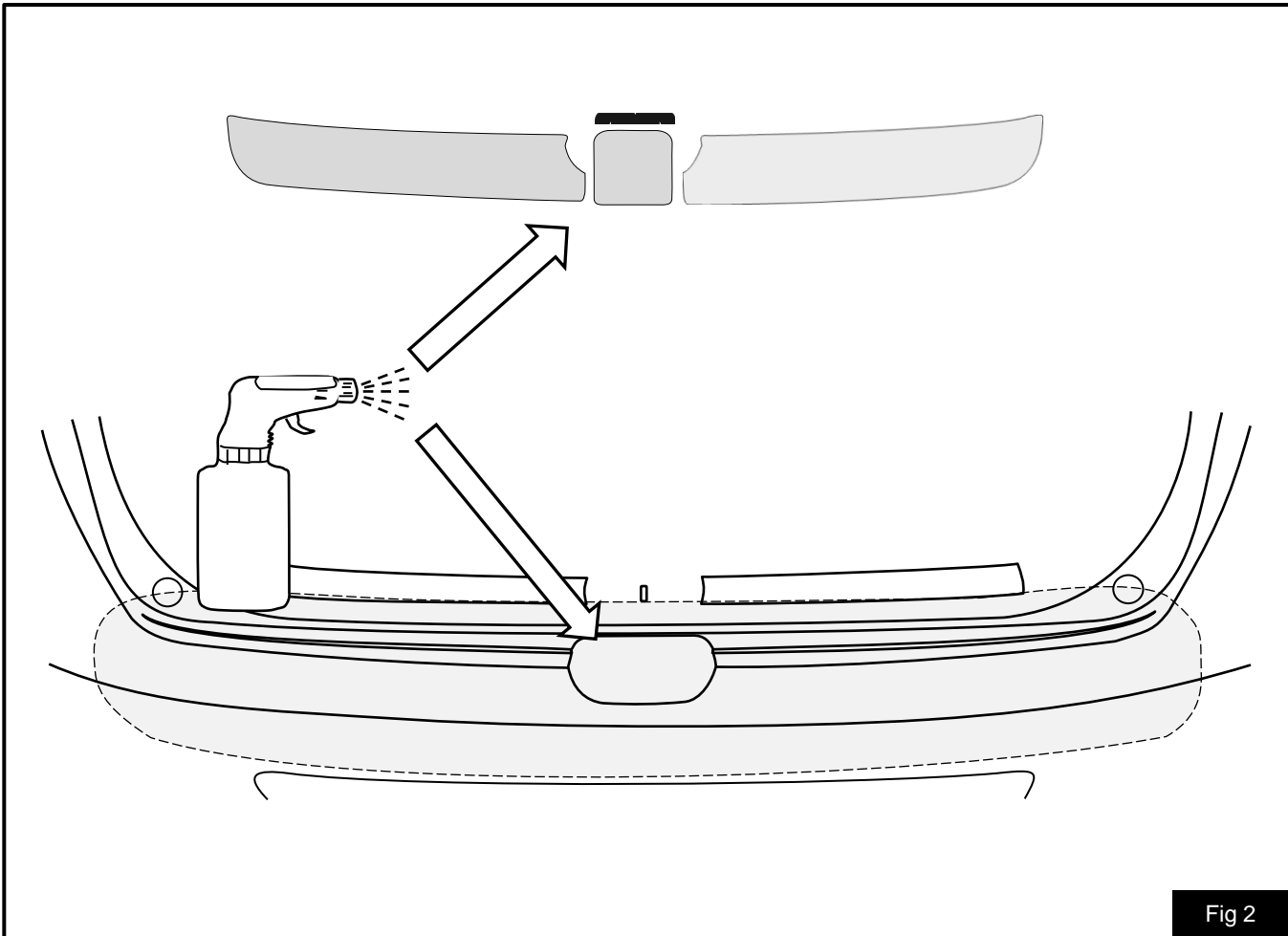

Fig 2

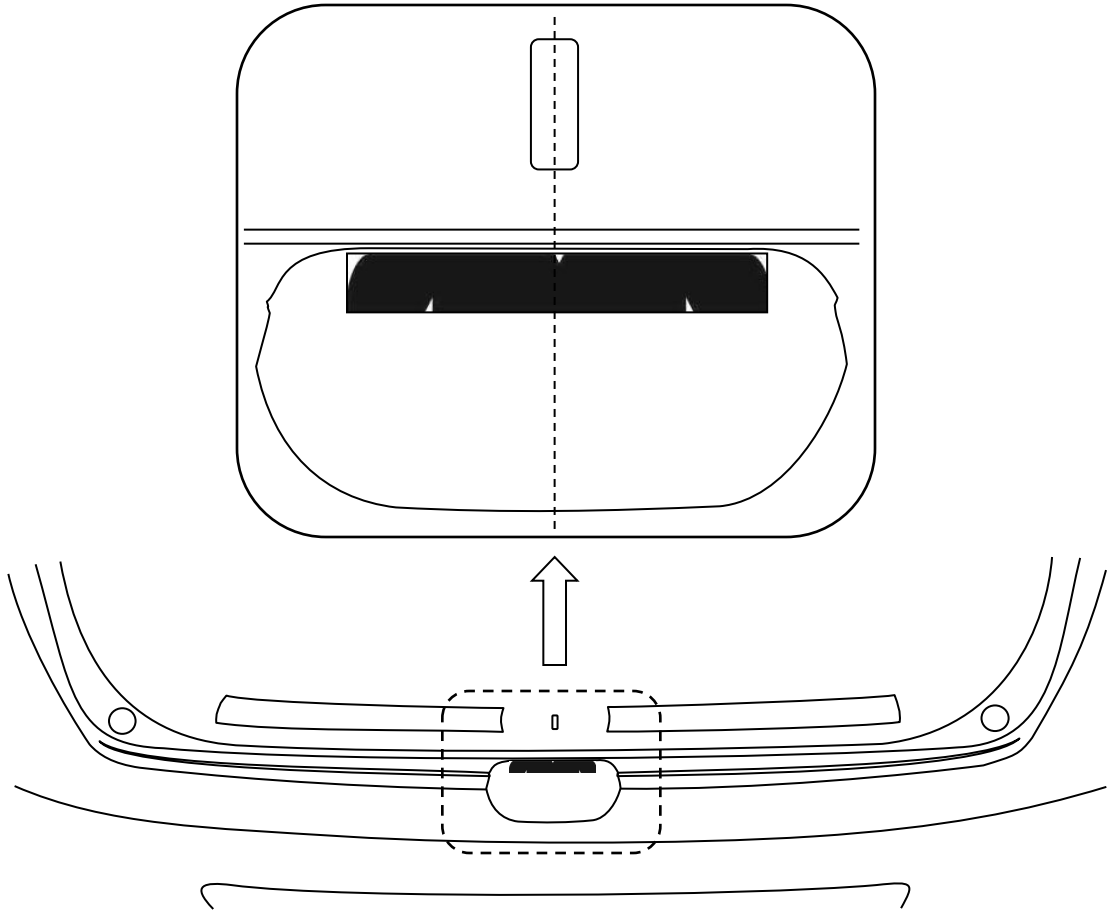

Fig 3

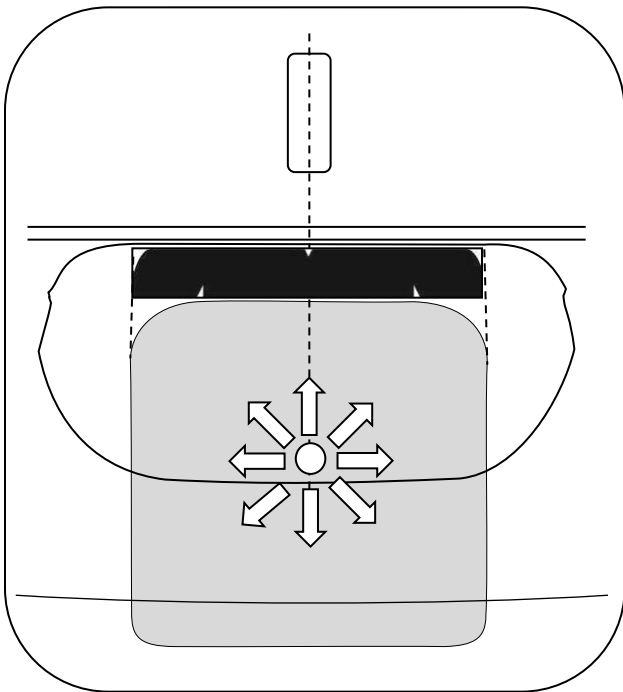

Fig 4

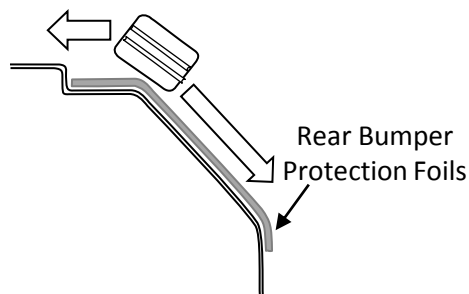
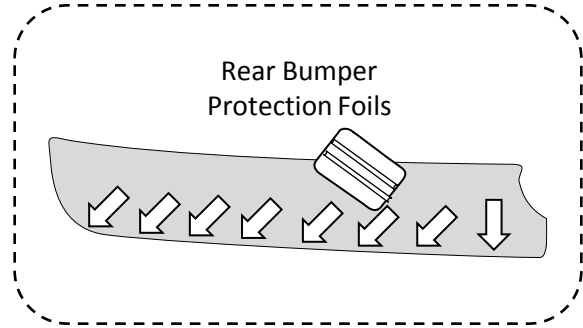
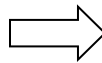
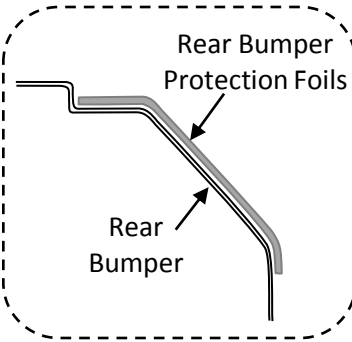
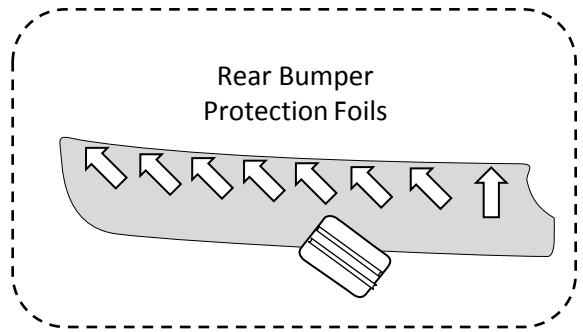
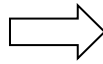
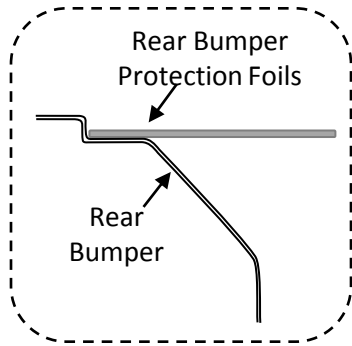
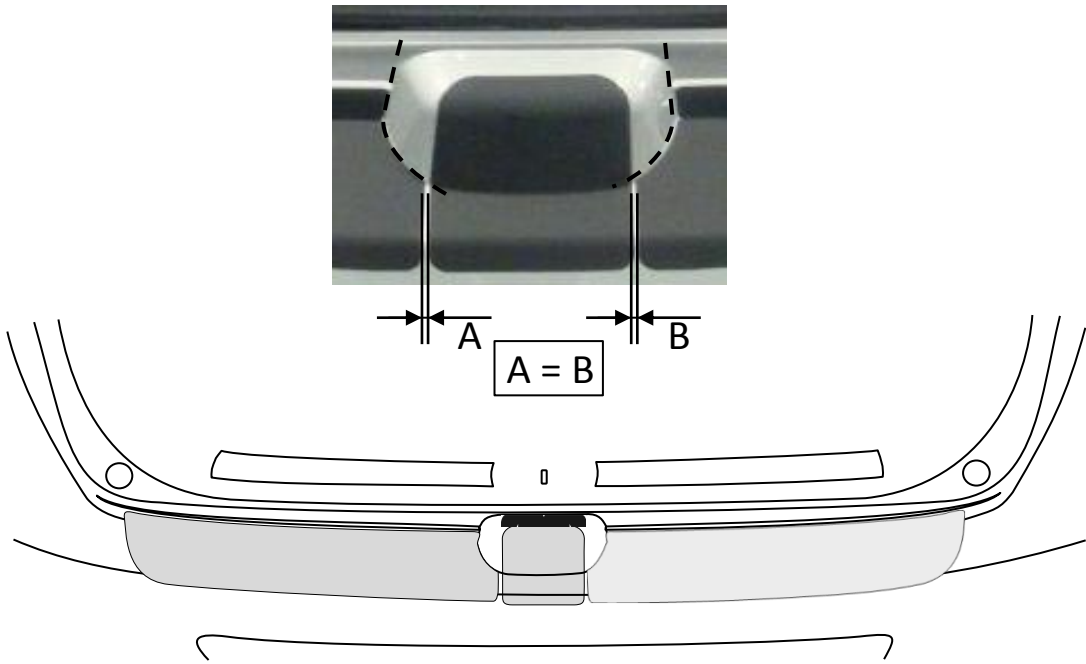

Fig 5

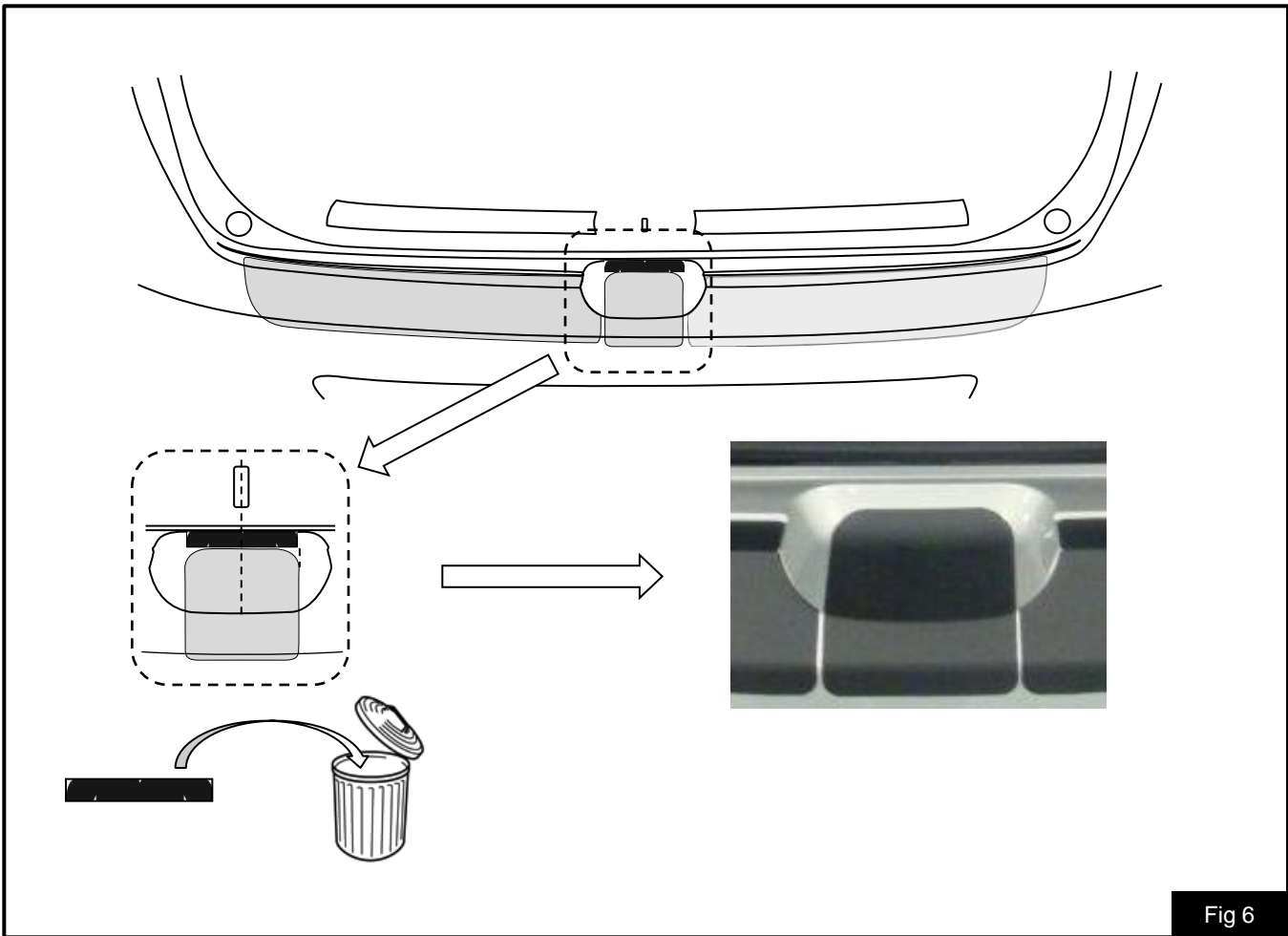

Fig 6



Fig 7