



INSTALLATION INSTRUCTIONS

Accessory	Application	Publications No.
MOONROOF VISOR P/N 08R01-TBG-100	2016 CIVIC 2-DOOR	VERSION 1
		Issue Date FEB 2016

PARTS LIST

Moonroof visor



2 Brackets "A"
(Identification mark: TBA A)



Right bracket "B"
(Identification mark: TBA-R B)



Left bracket "B"
(Identification mark: TBA-L B)



4 Screws



4 Nuts



2 Alcohol swabs



4 Protective films



TOOLS AND SUPPLIES REQUIRED

- Phillips screwdriver
- 10 mm Offset wrench
- Ruler
- Shop towel
- Masking tape
- Felt-tip pen
- High-quality paste wax

The following tool is available through the Honda Tool and Equipment Program. On the iN, click on: Service > Service Bay > Tool and Equipment Program, then enter the number under "Search." Or, call 888-424-6857.

- Torque Screwdriver (T/N CDI401SM)

INSTALLATION

Customer Information: The information in this installation instruction is intended for use only by skilled technicians who have the proper tools, equipment, and training to correctly and safely add equipment to your vehicle. These procedures should not be attempted by "do-it-yourselfers."

NOTE:

- Be careful not to damage the body paint finish.
- This moonroof visor kit should be installed only if the ambient air temperature is 15° C (60° F) or above.
- To allow the adhesive to cure, do not wash the vehicle for 24 hours. Make sure your customer is aware of this.

1. Clean and wax the area to be covered with a high-quality paste wax.
2. Open the moonroof. Roll up two shop towels, and insert them between the roof panel and air deflector to lower the air deflector.
NOTE: Be careful not to damage the air deflector.

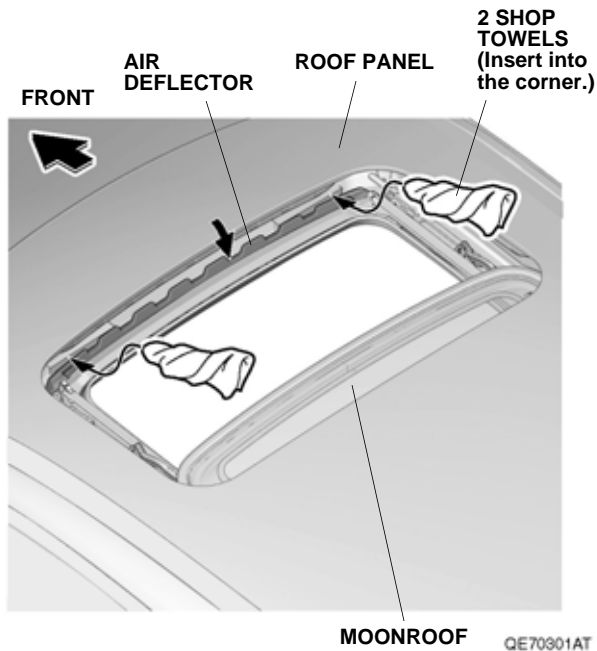

3. Measure and make two marks on the roof panel as shown.

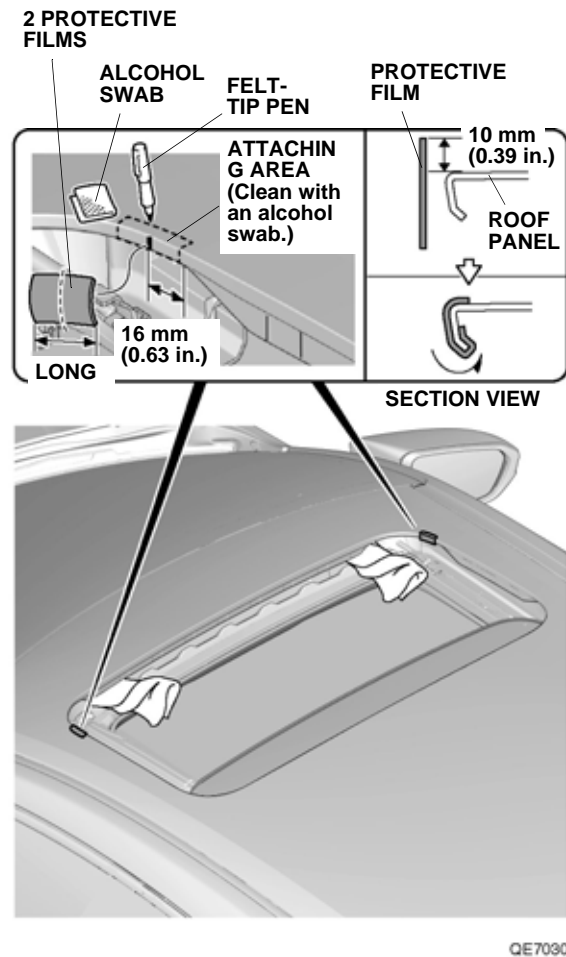

4. Using an alcohol swab, clean the roof panel at each of the two marks you made, but do not wipe off the marks.
5. Remove the adhesive backing from the two protective films, and attach them to the roof panel at the two marks.

6. Locate the third indentations from the side of the moonroof opening. Using an alcohol swab, clean the roof panel where the protective films will attach.

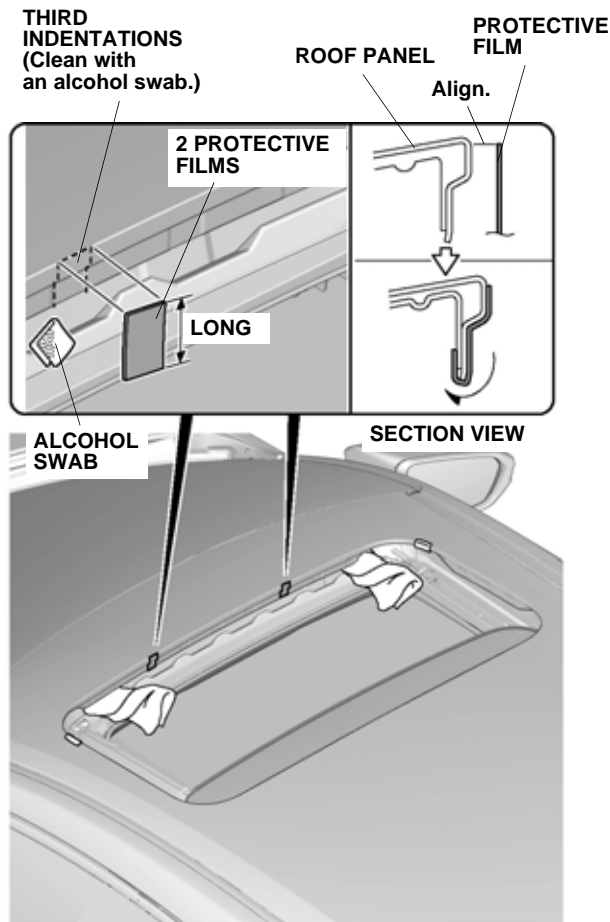

QE70303BT

7. Remove the adhesive backing from the two protective films, and attach them to the roof panel at third indentation.

8. Place the left and right brackets "B" into position over the two protective films and around the lip of the roof panel, and tape them into position.

NOTE: Be careful not to crease the protective film.

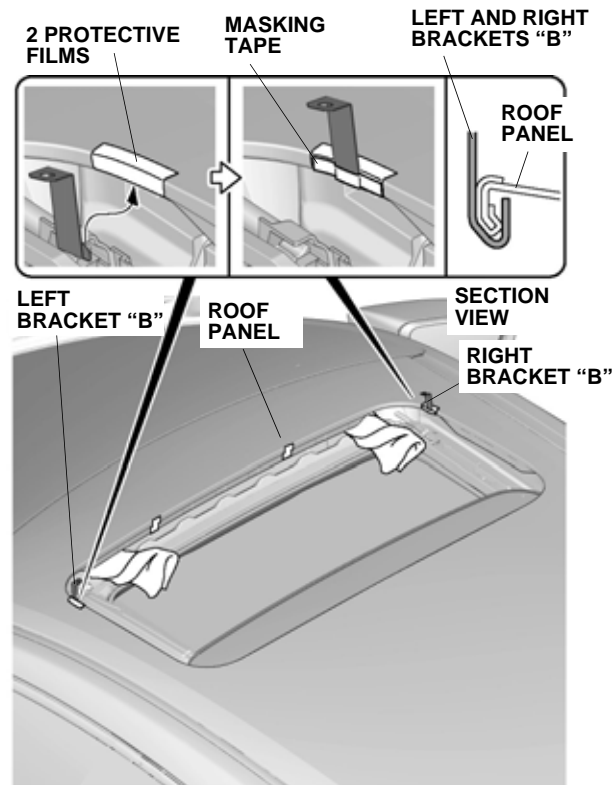

QE70304BT

9. Place two brackets "A" into position over the two protective films and around the lip of the roof panel, and tape them into position with masking tape. Be sure to align the lower end of the brackets "A" with the third indentation.

NOTE: Be careful not to crease the protective film.

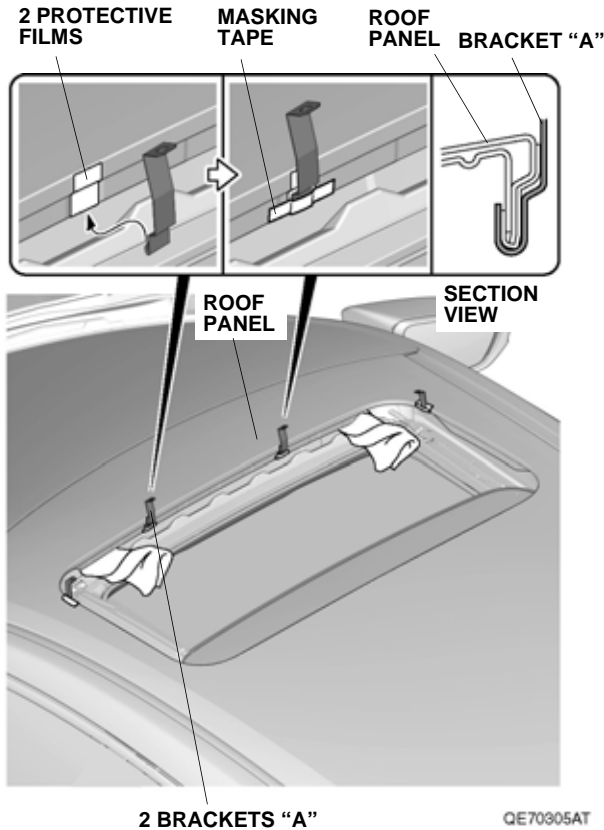

10. Set the moonroof visor on the vehicle roof in front of the moonroof opening, and adjust its position so the holes in the moonroof visor are aligned with the bracket "A" holes. Loosely install the moonroof visor to the brackets "A" with two screws and two nuts. Remove the strips of masking tape from the brackets "A".

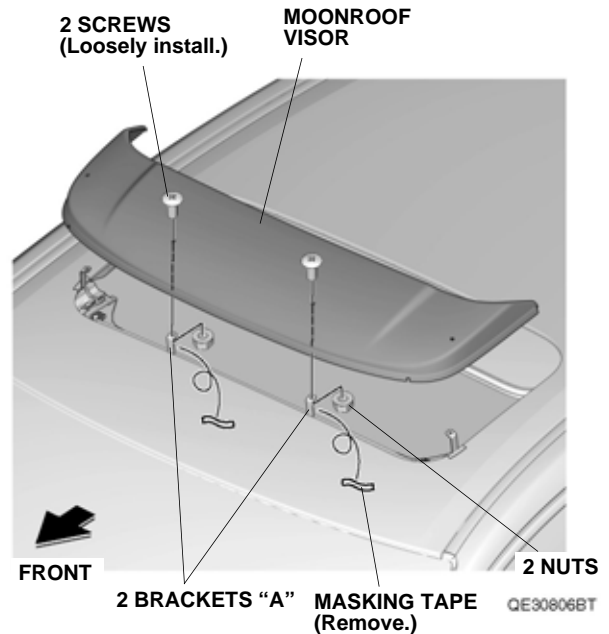

11. Loosely install the moonroof visor to the left and right brackets "B" with two screws and two nuts. Remove the masking tape from the left and right brackets "B".

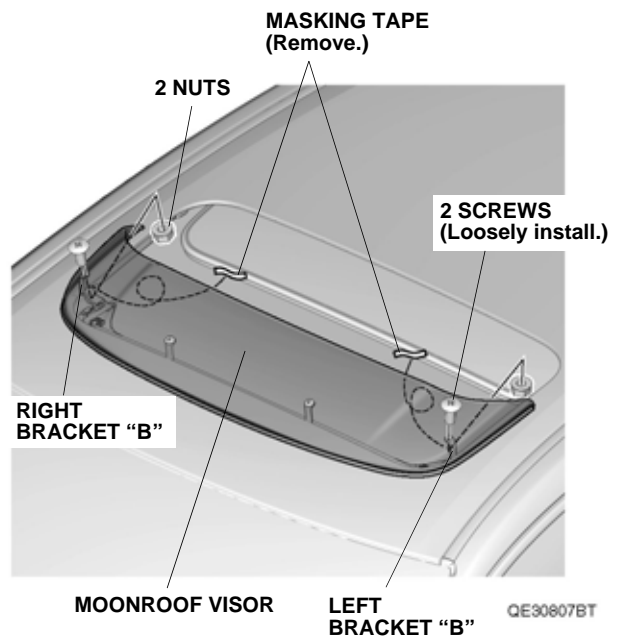

12. Check the information of the **IMPORTANT INFORMATION** label. To avoid wind noise, install the brackets against the body.

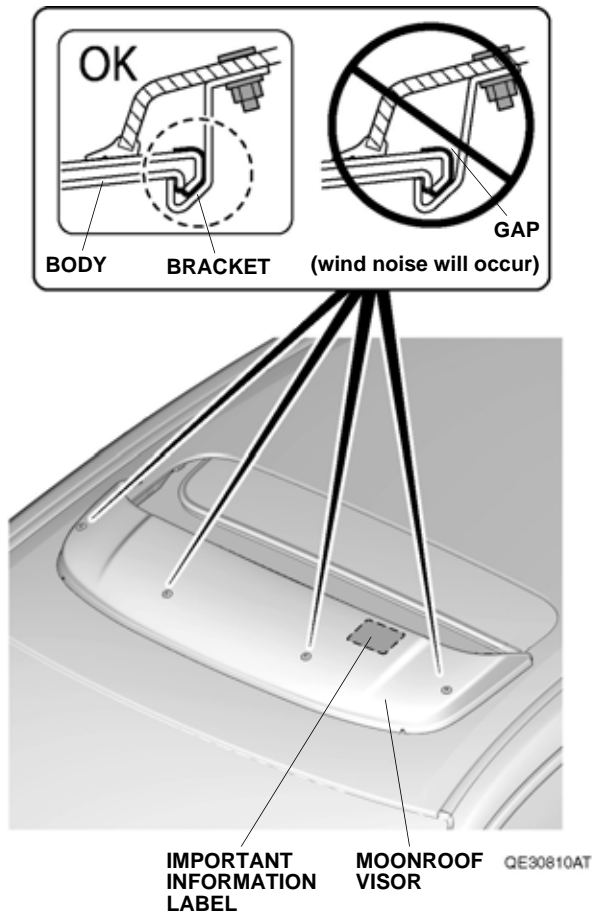

13. Position the moonroof visor with equal spacing in the front and on the sides. Check that the rubber molding is not twisted or rolled under the moonroof visor.

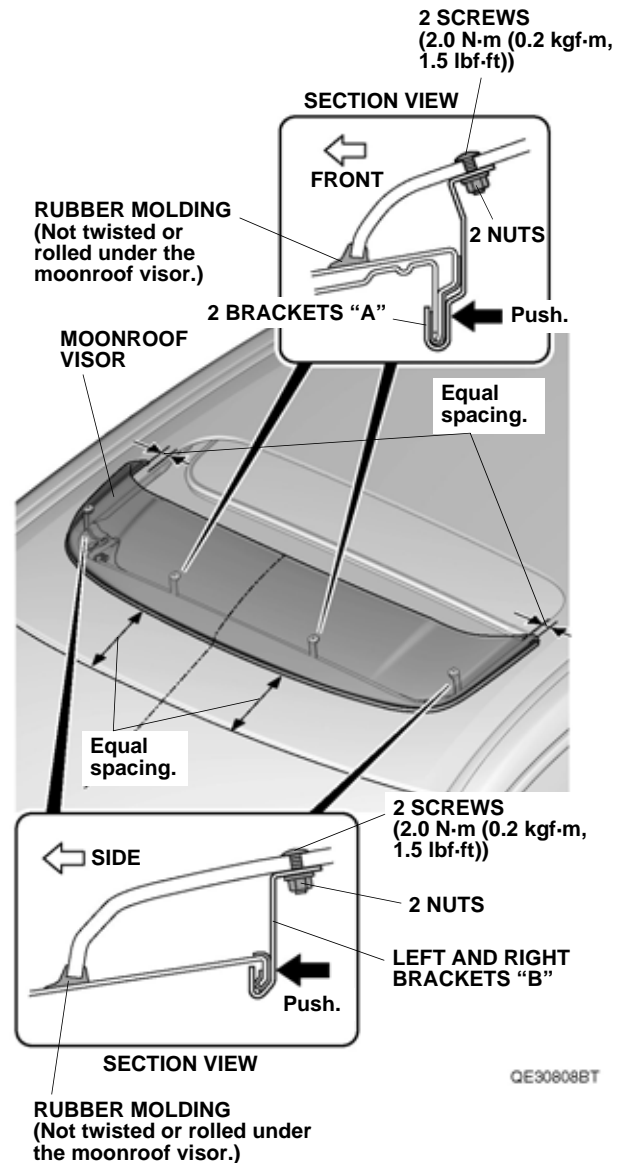

14. Tighten two screws and two nuts on the front of the vehicle first, then tighten two screws and two nuts on each side. Tighten while applying pressure so that there is no gap between the roof panel and the brackets "A" and "B". Torque the screws to 2.0 N·m (1.5 lbf·ft).

15. Remove the shop towels inserted in step 2. Remove the IMPORTANT INFORMATION label.

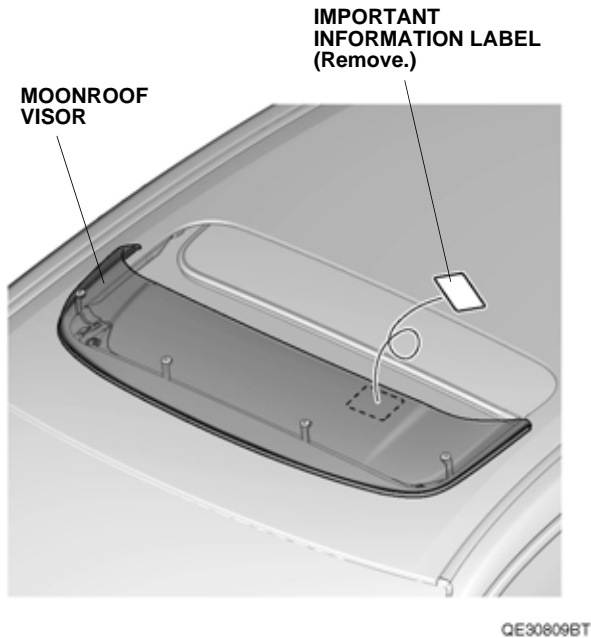

CARE OF THE MOONROOF VISOR

- To avoid damaging the surface, do not use organic solvents such as gasoline, ammonia-based cleaners, or solvents to clean the moonroof visor.
- Clean with neutral detergent solution and water using a soft cloth or chamois.
- To remove fine scratches and restore the original luster, use Meguiar's Mirror Glaze plastic cleaner and polish or an equivalent high-quality plastic cleaner.