



INSTALLATION INSTRUCTIONS

Accessory
SPLASH GUARDS
 P/N 08P00-T2A-100

Application
2014 ACCORD
 4-DOOR

Publications No.
All 49984

Issue Date
AUG 2013

PARTS LIST

Left front splash guard



Right front splash guard



Left rear splash guard



Right rear splash guard



8 Washer-screws

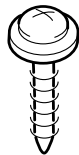

2 Spring nuts



TOOL AND SUPPLIES REQUIRED

- Phillips screwdriver
- Pushpin
- Stubby Phillips screwdriver
- Utility knife

The following tool is available through the Honda Tool and Equipment Program. On the iN, click on: Service > Service Bay > Tool and Equipment Program, then enter the number under "Search". Or, call 888-424-6857.

- Trim Tool Set (T/N SOJATP2014)

Illustration of the Splash Guards on the Vehicle

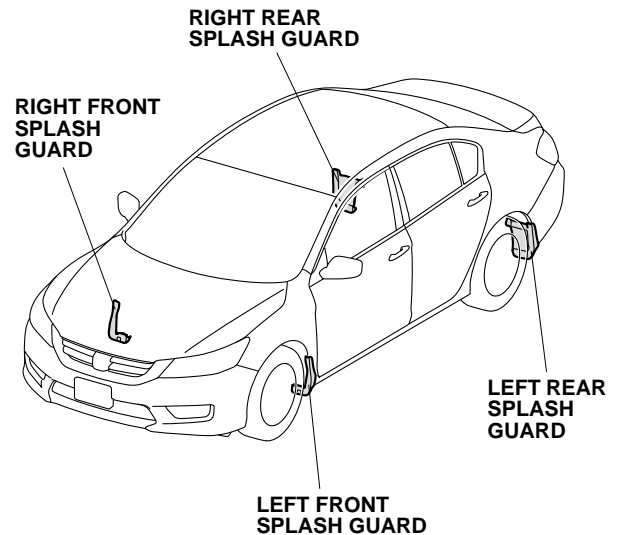

QB13102AB

INSTALLATION

Customer Information: The information in this installation instruction is intended for use only by skilled technicians who have the proper tools, equipment, and training to correctly and safely add equipment to your vehicle. These procedures should not be attempted by "do-it-yourselfers."

NOTE:

- Do not damage the paint finish.
- Clean and wax the areas to be covered with a high-quality paste wax.

Installing the Front Splash Guards

1. Turn the steering wheel fully counterclockwise.

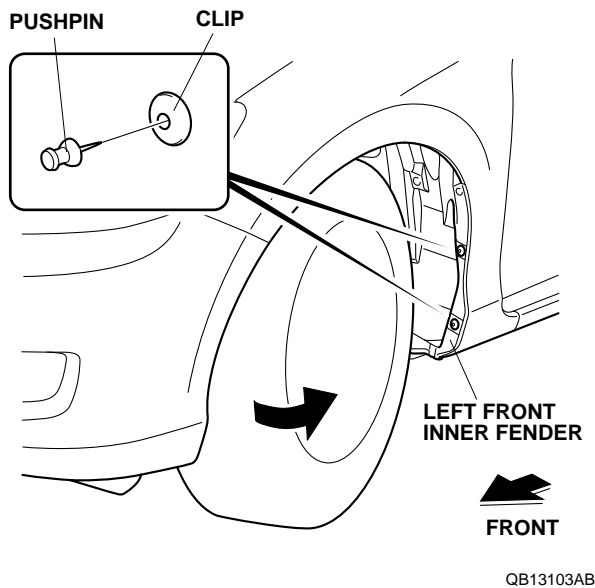

2. Using a pushpin, pierce the center of the two clips in the left front inner fender.
3. Remove the lower clip from the left front inner fender.

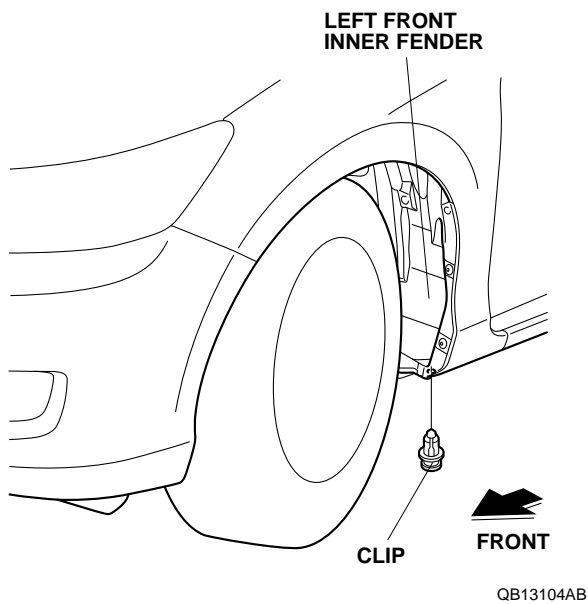

4. Install the left front splash guard to the left front inner fender with two washer-screws and the clip removed in step 3. Install the screws in this order **1** → **2** → **3**. If necessary, trim the sealant. Make sure there is no gap between the left front splash guard and the vehicle body. If there is a gap, loosen the two washer-screws, hold the splash guard against the body, and retighten the washer-screws.

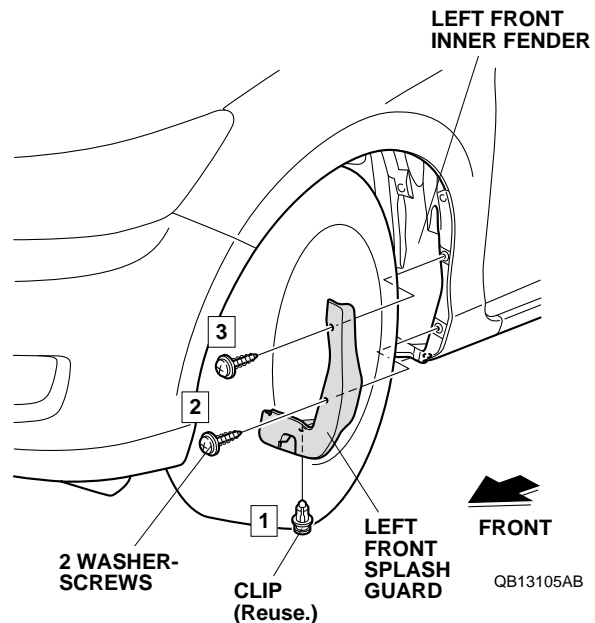

5. Turn the steering wheel fully clockwise, and repeat steps 2 through 4 to install the right front splash guard.

Installing the Rear Splash Guards

6. Remove and discard one screw from the rear bumper.

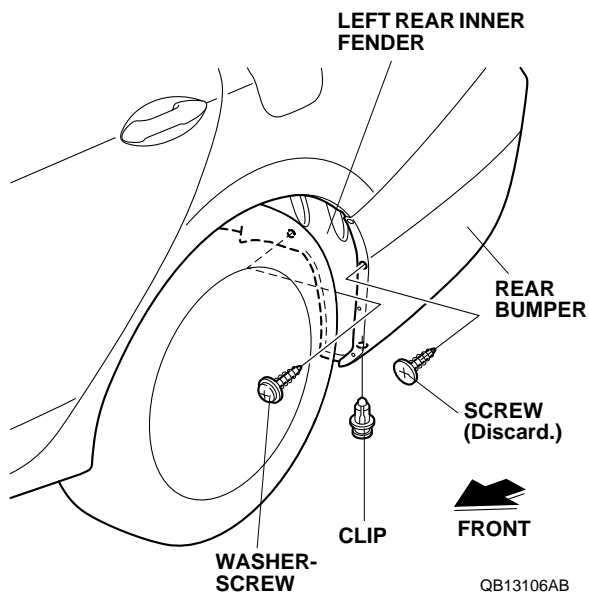

7. Remove one washer-screw and one clip from the left rear inner fender and rear bumper.
8. Using a pushpin, pierce the rear bumper at the dimple.

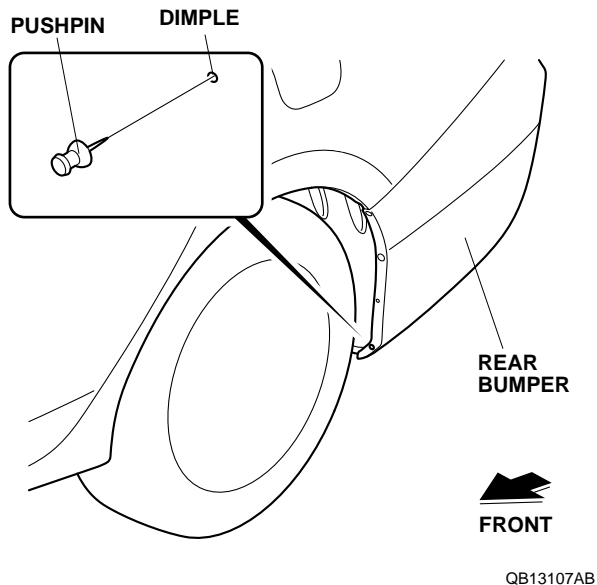

9. Pull away the rear bumper. Use a utility knife to cut the left rear inner fender in the area shown.

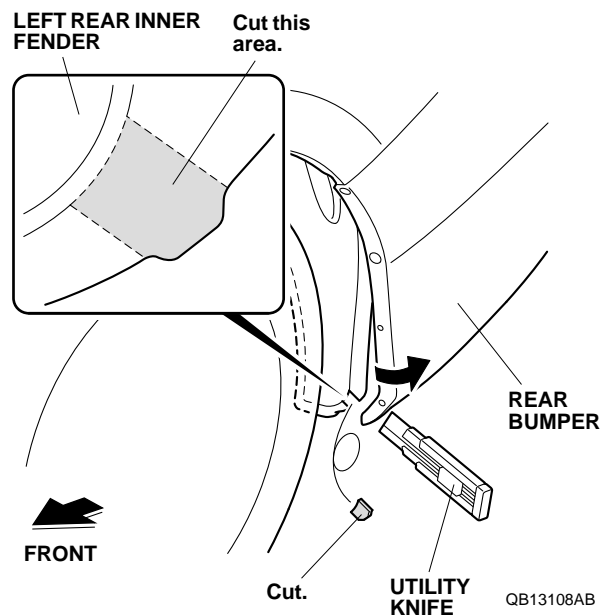

10. Reinstall the rear bumper back into its original position.
11. Reinstall the clip removed in step 7.
12. Install a spring nut over the hole in the rear bumper. Install the spring nut in the direction shown.

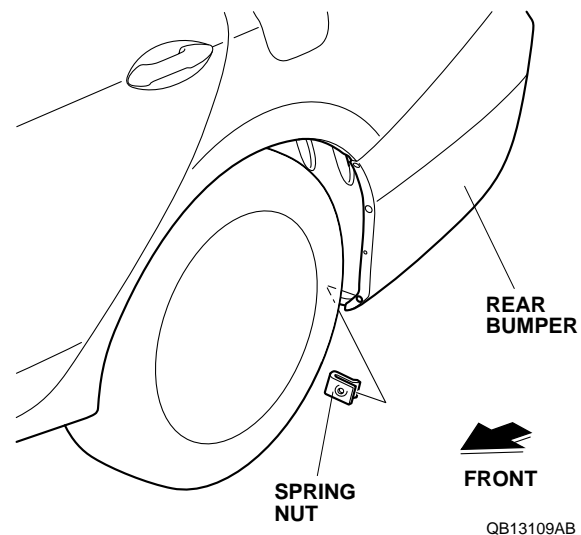

13. Install the left rear splash guard to the rear bumper with two new washer-screws and the washer-screw removed in step 7. Install them in this order **1** → **2** → **3**. Make sure there is no gap between the left rear splash guard and the vehicle body. If there is a gap, loosen the washer-screws, hold the splash guard against the body, and retighten the washer-screws.

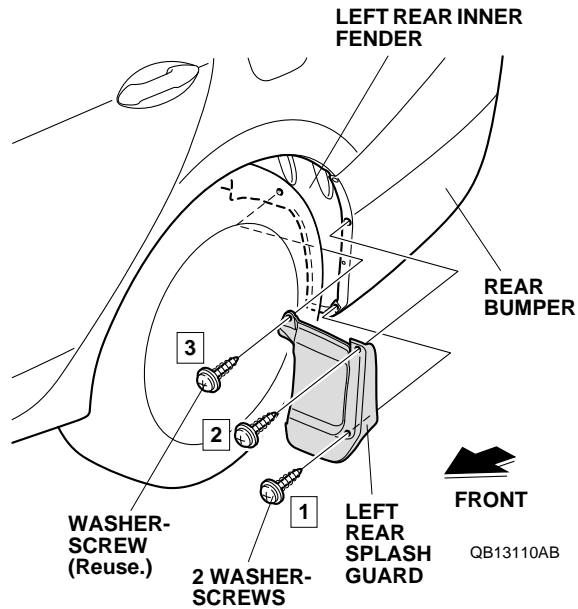

14. Repeat steps 6 through 13 to install the right rear splash guard.